

Returns & Faulty Items

- If any problem is encountered during or after installation, please call the All LED technical department to get the problem resolved as soon as possible.
- Please do not just return the item to the outlet you purchased it from, as you are only entitled to a replacement or refund after the unit has undergone testing and the unit has been confirmed as having a manufacturing defect/fault. Your statutory rights are not affected.
- The manufacturer will not be deemed liable or held responsible for any damages caused by faults or manufacturing defects that may be present in any of its products or the misuse or incorrect installation of this device. Please refer to our troubleshooting guide for further information.
- All goods are supplied under the terms and conditions of All LED LTD, a copy of which may be obtained upon written request.

General Information

- Interference may occur with other products on the same frequency of 2.4Ghz
- Product may differ in colour from image on box
- Range signal can be reduced when using within materials such as concrete & metal



INSTALLATION GUIDE



AiQ/DWC/WH iQ Intelligent Smart Control Wireless Door/Window Sensor



Technical Specifications

Product Code	AiQ/DWC/WH
Radio Frequency	2.4Ghz
Power Supply	3VDC (2x CR2450 Batteries)
Operating Temperature	0°C ~ +40°C

Dimensions

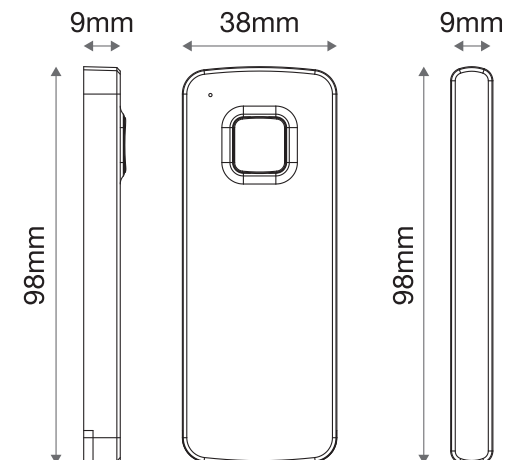

ALL LED LTD
42 Sedgwick Road,
Luton, LU4 9DT

www.allledgroup.com
sales@allledgroup.com
Tel: +44 (0)208 841 9000



Environmental Protection
Waste electrical products should
not be disposed of with household
waste. Please recycle where
facilities exist. Check with your
Local Authority or retailer for
recycling advice



The manufacturer will not be deemed liable or held responsible for any damages caused by faults or manufacturing defects that may be present in any of its products or the misuse or incorrect installation of this device
Your statutory rights are not affected.

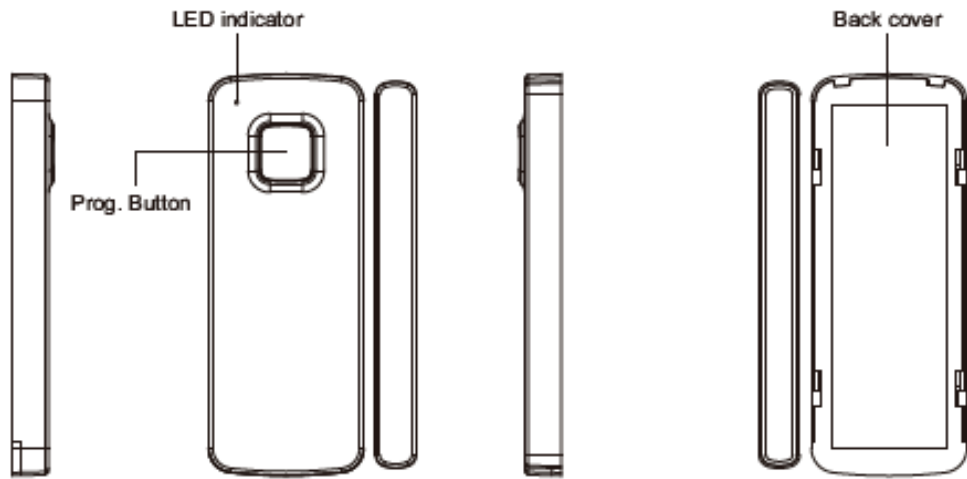

Installation Instructions

1. Stick the double-sided tape on the Sensor and magnet.
2. Peel the protective layer from double sided tape and stick the sensor on to the door/window
3. Peel the protective layer from double sided tape and stick the magnet on to the door/window. Make sure the magnet is within 10mm from sensor.

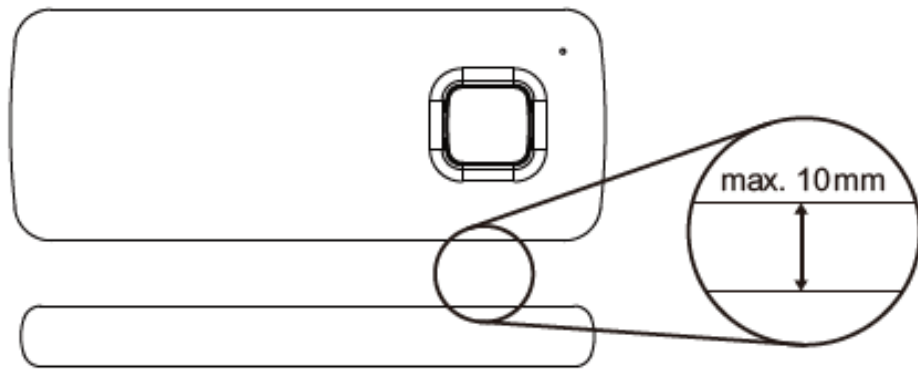

Connecting Sensor to Smart Hub

1. Enter Pairing mode on your smart Hub and follow instructions.

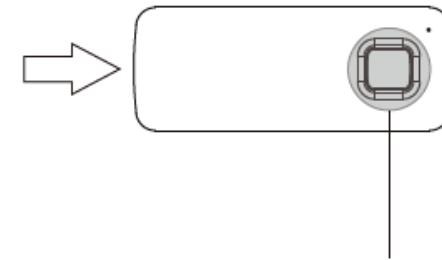

2. Press and hold the program button for 5 seconds until the LED indicator flashes three times. If the sensor has connected successful to your smart hub the LED indicator will rapidly flash.
3. Once connected the sensor will need to be setup in the Alexa app under routines or scenes to work with other smart devices. Please follow Smart Hub instructions.

Factory Reset

1. Press and hold the program button for 5s until the LED indicator flashes three times.

